

# ADEGA DAKAR

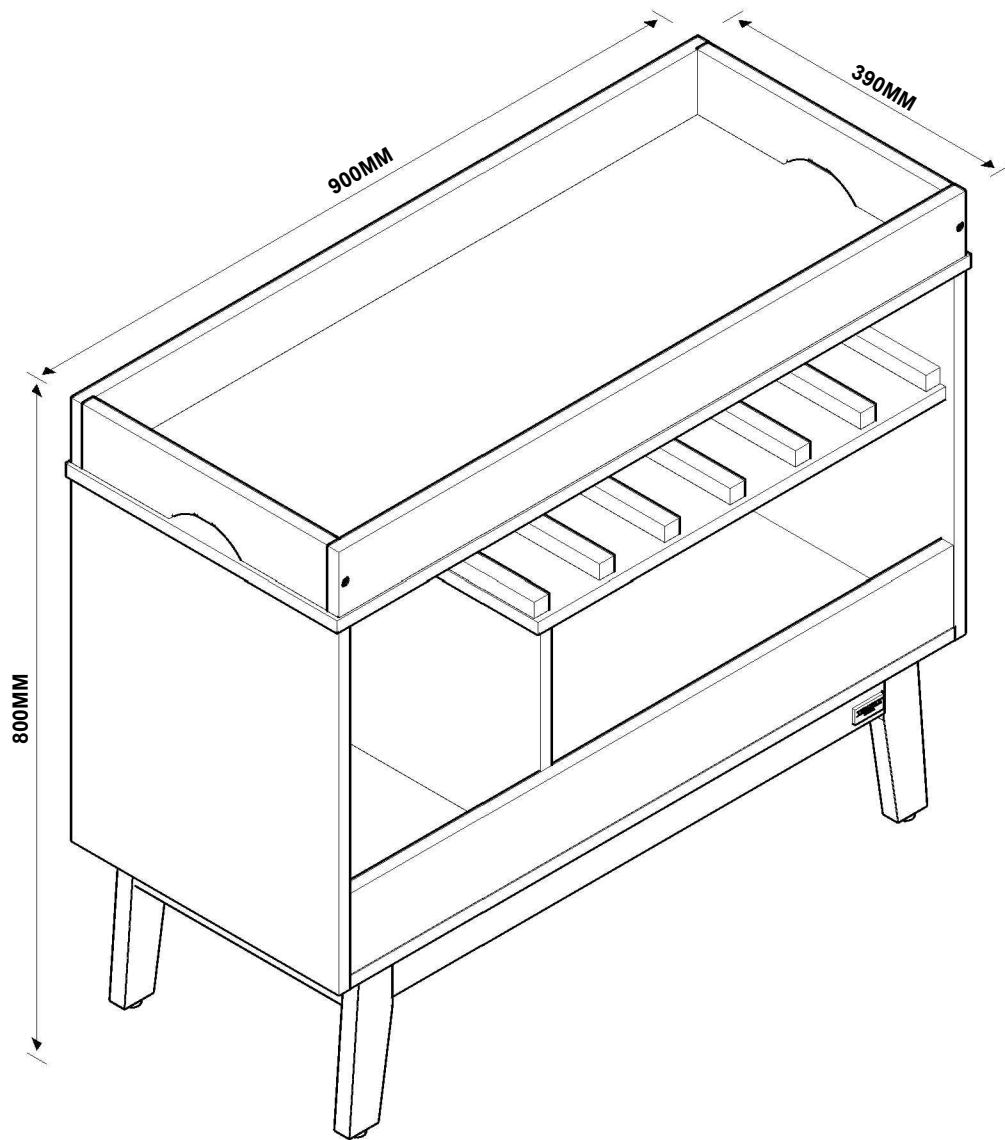

# (CAPACIDADE DE CARGA)

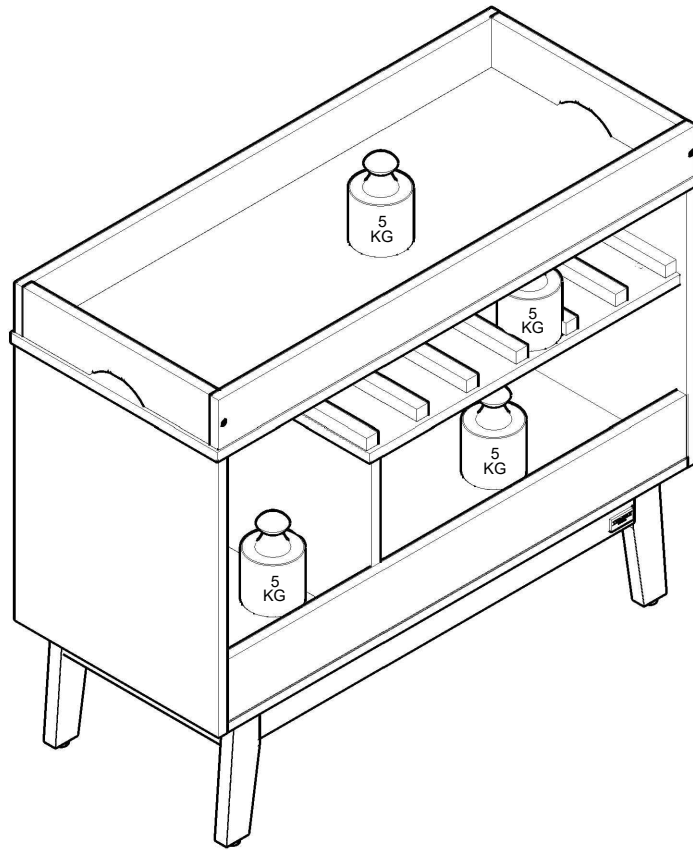

(17) 3485- 9300

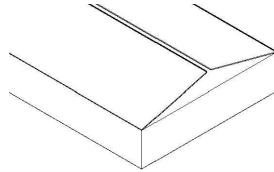

NECESSÁRIO PARA MONTAGEM  
(NÃO FORNECIDO)



BARRA ROSCADA 1/4X85MM (08)

J

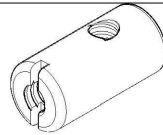

PORCA CILINDRICA 2 FUROS 1/4 (04)

Q

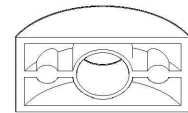

ARRUELA MEIA LUA BAIXA 1/4 (08)

O

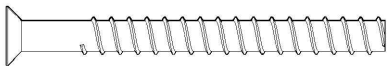

PARAFUSO 5,0X50MM ESCAREADO (10)

L



PARAFUSO 4,0X14MM CHATA (36)

AD



PINO MINIFIX (12)

M



CAVILHA 06X30MM (14)

S



PORCA SEXTAVADA 1/4 (08)

R

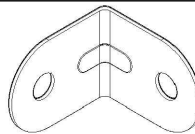

CANTONEIRA 18X18X14 (10)

D

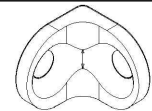

CANTONEIRA ZAMAC MACIÇA 2 FUROS (06)

Z

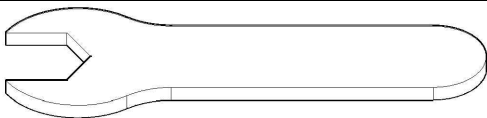

CHAVE 10MM (01)

T

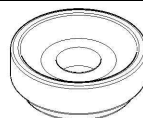

SAPATA SAMURAI RED. 22MM PRETA (04)

AF

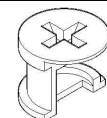

TAMBOR MINIFIX 12X10 (12)

N

TEBARROT  
DO BRASIL

ETIQUETA TEBARROT (01)

AP

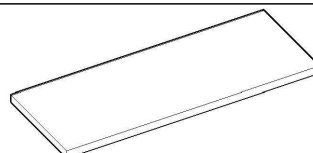

FITA DUPLA FACE (07)

EH

REF.	COD.	Descrição das Peças	Medidas/				Vol.	Qt.	
01	51	TAMPO	0,900	x	0,385	x	0,015	1 / 1	1
02	41	LATERAL DIREITA	0,450	x	0,380	x	0,015	1 / 1	1
03	42	LATERAL ESQUERDA	0,450	x	0,380	x	0,015	1 / 1	1
04	66	BASE	0,860	x	0,380	x	0,015	1 / 1	1
05	458	BASE ADEGA	0,580	x	0,355	x	0,015	1 / 1	1
06	162	DIVISÓRIA CENTRAL	0,347	x	0,275	x	0,015	1 / 1	1
07	459	TRAVESSA SUPERIOR MAIOR	0,890	x	0,080	x	0,015	1 / 1	2
08	15	TRAVESSA SUPERIOR	0,350	x	0,080	x	0,015	1 / 1	2
09	149	TRAVESSA INFERIOR	0,860	x	0,100	x	0,015	1 / 1	2
10	401	PÉ 1 (MAD.)	0,250	x	0,060	x	0,020	1 / 1	2
11	402	PÉ 2 (MAD.)	0,250	x	0,060	x	0,020	1 / 1	2
12	407	TRAVESSA MAIOR (MAD.)	0,700	x	0,060	x	0,020	1 / 1	2
13	406	TRAVESSA MENOR (MAD.)	0,300	x	0,060	x	0,020	1 / 1	2
14	460	ACABAMENTO ADEGA (MAD.)	0,340	x	0,020	x	0,020	1 / 1	7
15	461	GUIA ACABAMENTO ADEGA	0,200	x	0,070	x	0,003	1 / 1	1

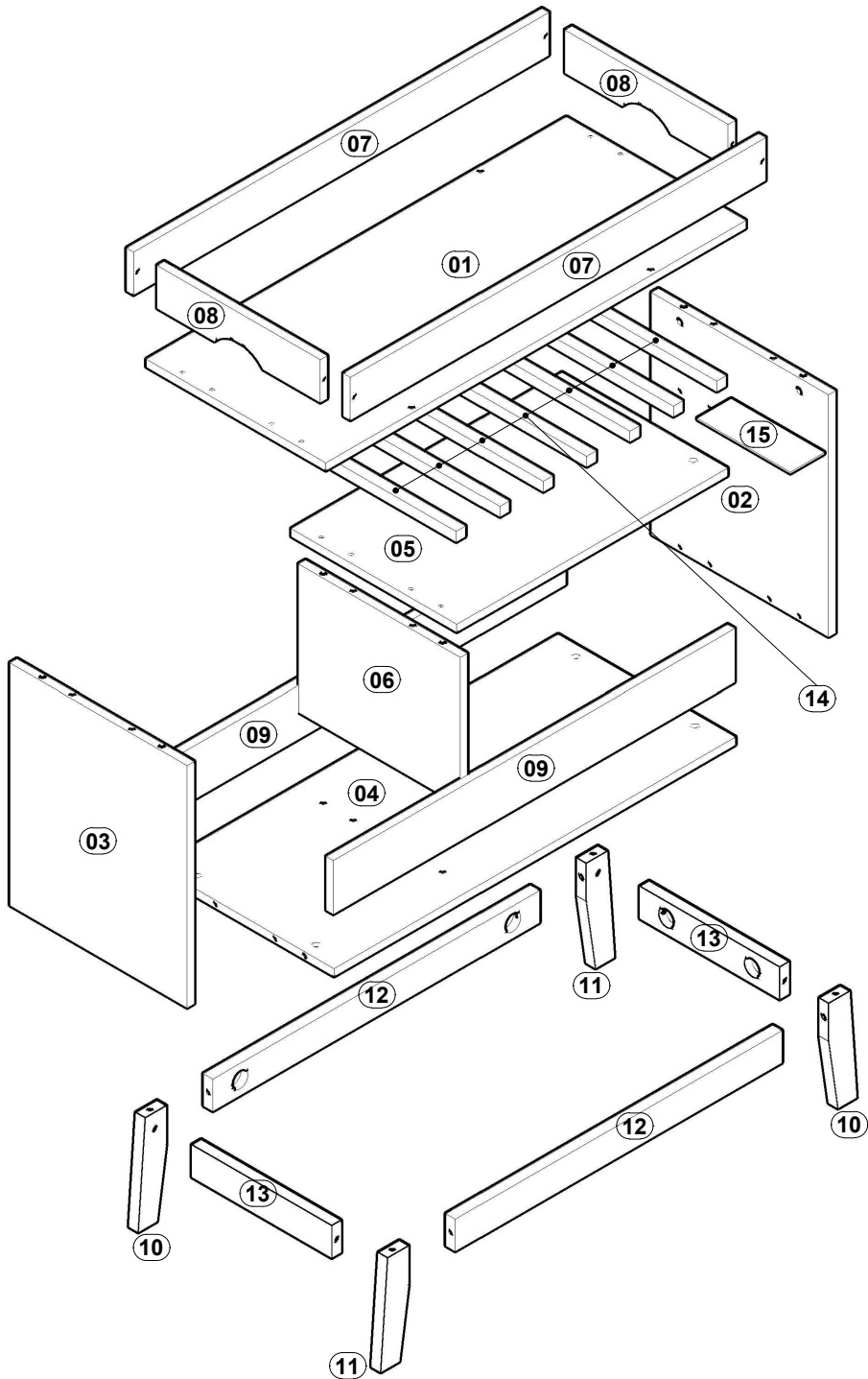

# 1°

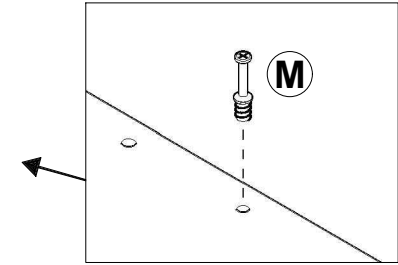
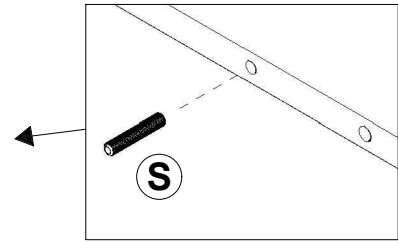
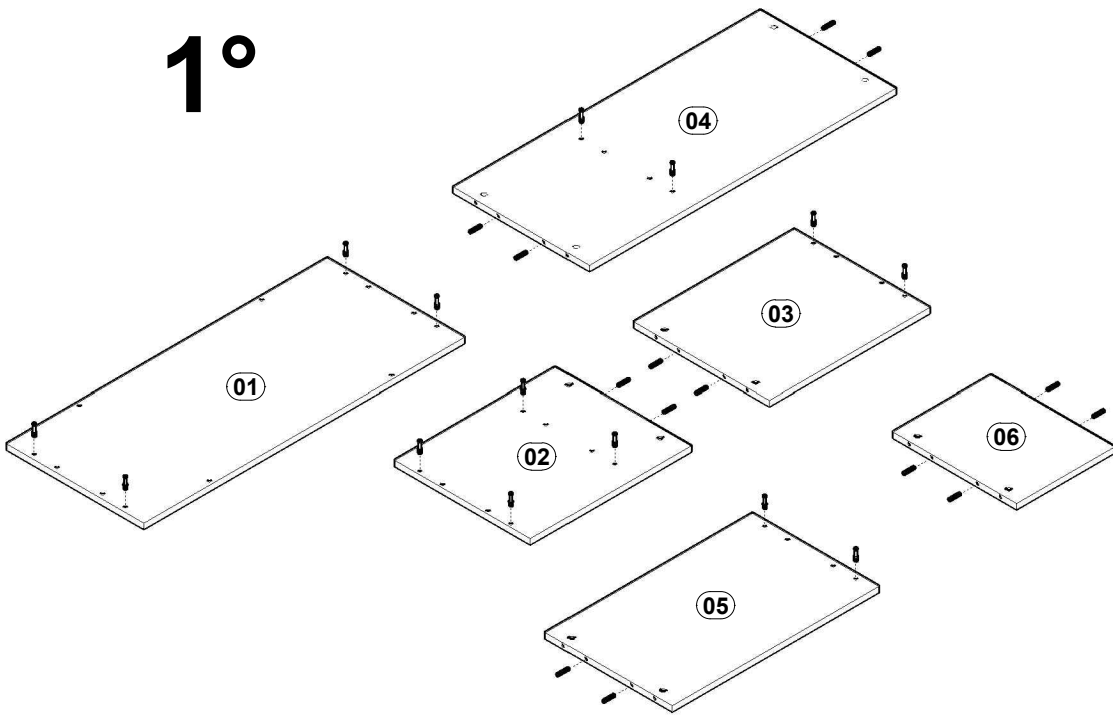

# 2°

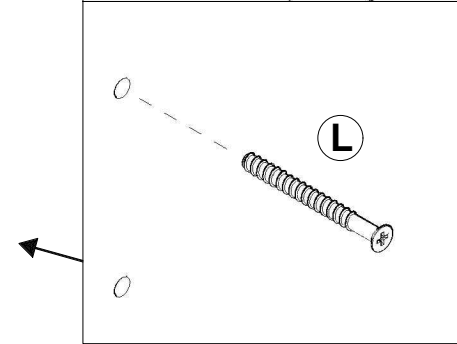
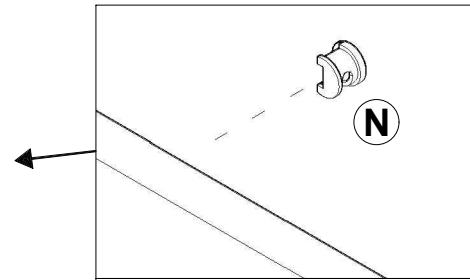
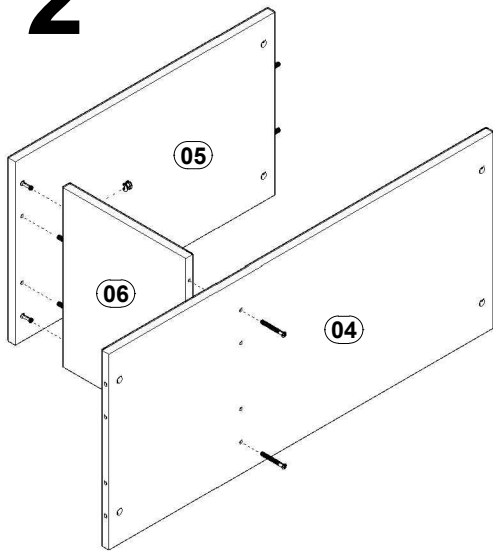

# 3°

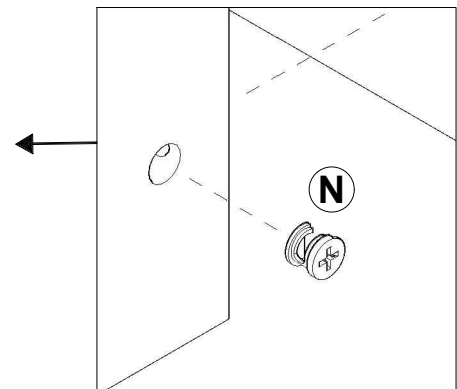
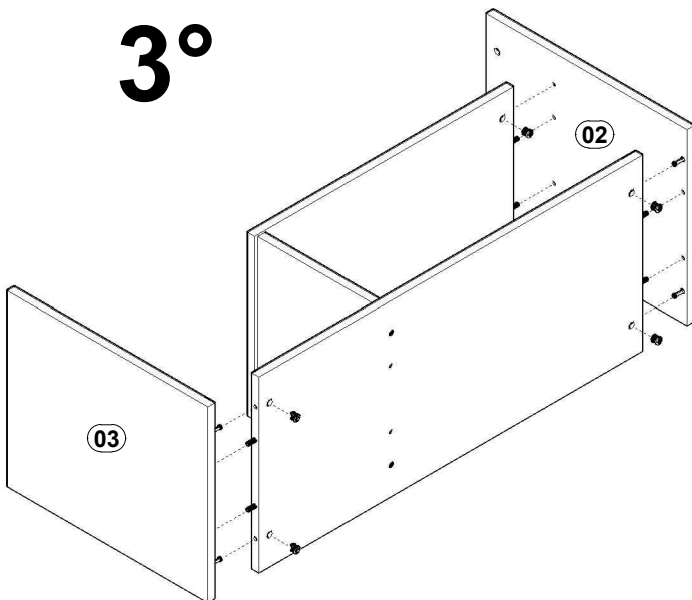

# 4°

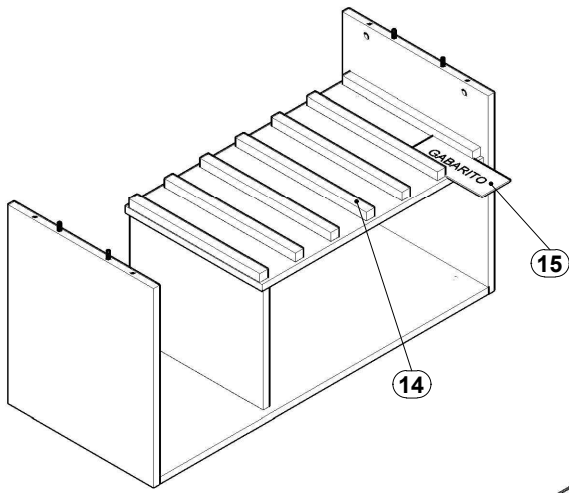

**OBS:** CORTAR A DUPLA FACE AO MEIO NO COMPRIMENTO, E FIXAR NA PEÇA 14.

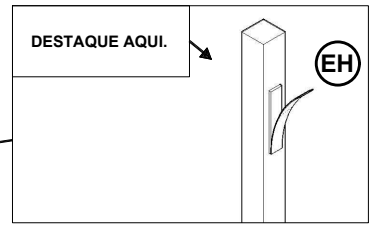
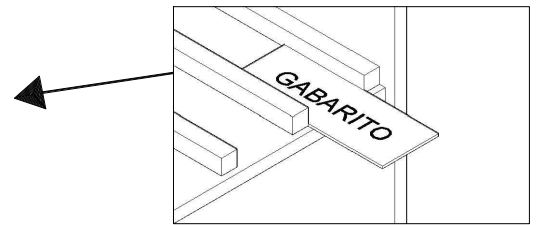
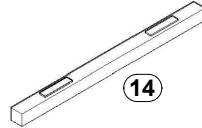
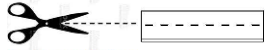

# 5°

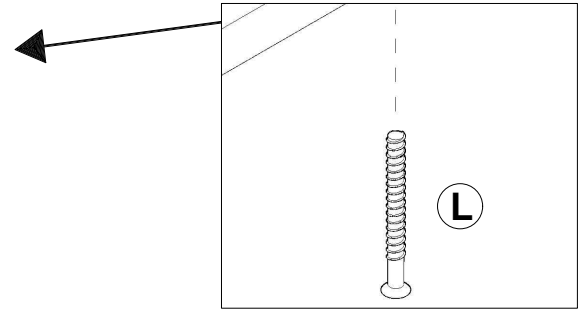
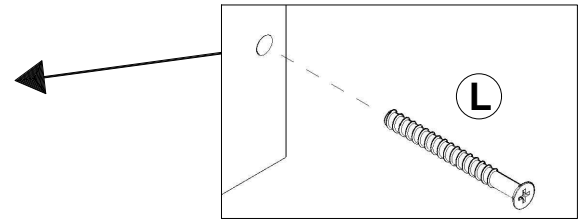
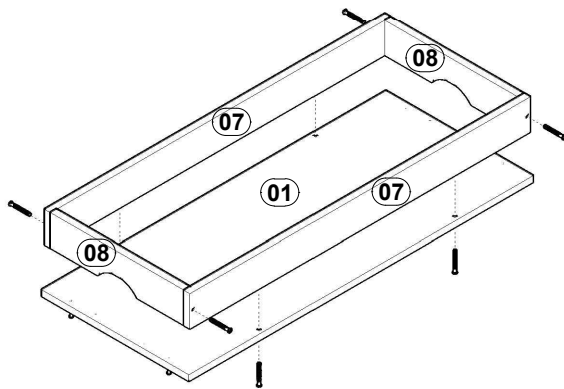

# 6°

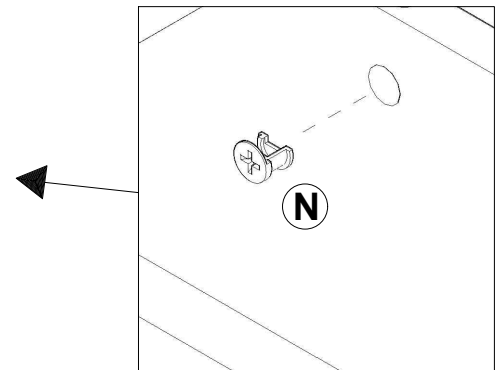
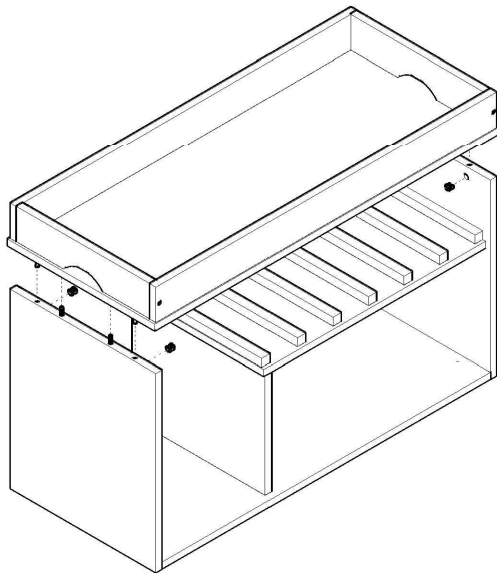

# 7°

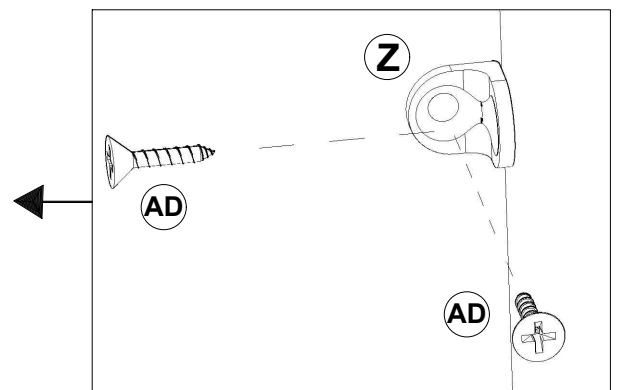
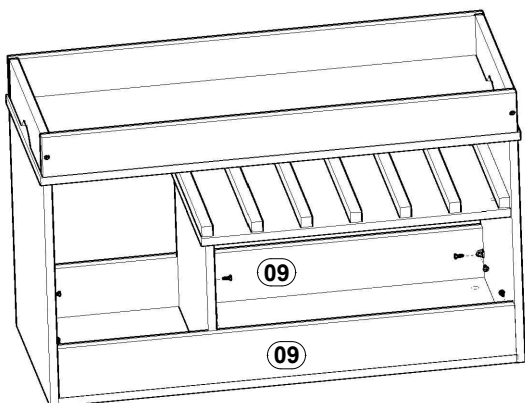

8°

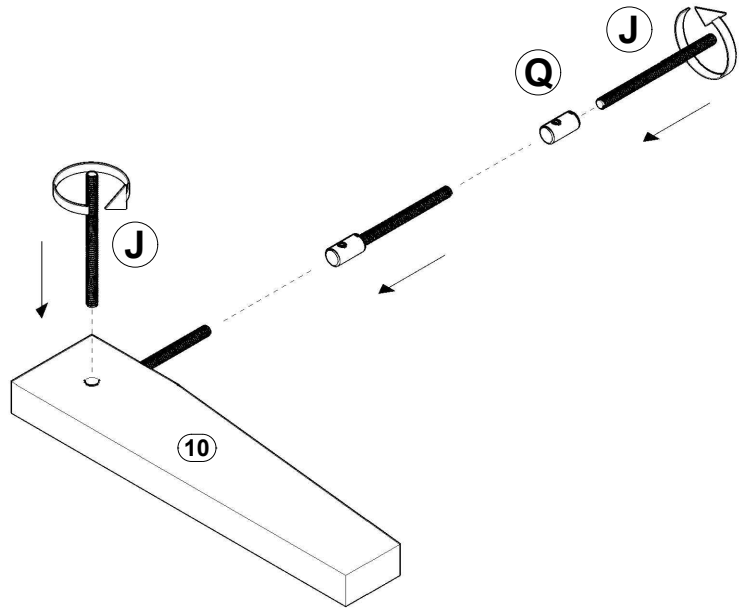

9°

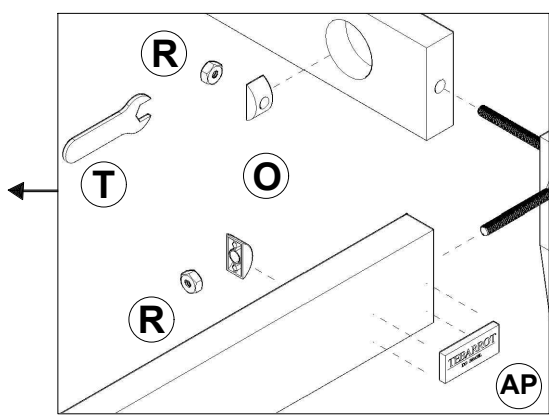
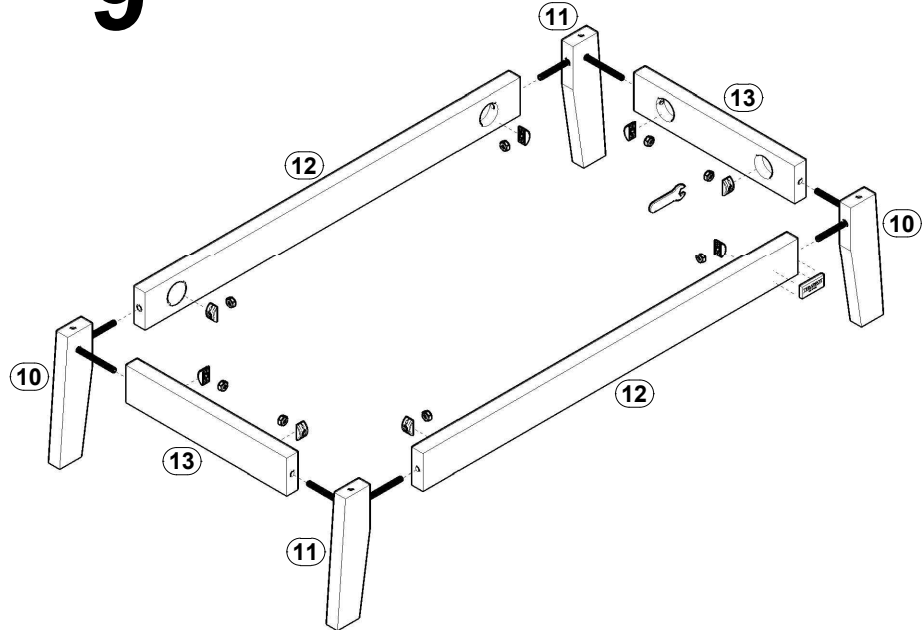

10°

